

Draft-stopping & Fire-stopping

R302.12 Draft-stopping required. When there is usable space both above and below the concealed space of a floor/ceiling assembly, draftstops shall be installed so that the area of the concealed space does not exceed 1,000 square feet (92.9 m²). Draftstopping shall divide the concealed space into approximately equal areas. Where the assembly is enclosed by a floor membrane above and a ceiling membrane below draftstopping shall be provided in floor/ceiling assemblies under the following circumstances:

1. Ceiling is suspended under the floor framing.
2. Floor framing is constructed of truss type open web or perforated members.

R302.12.1 Materials. Draftstopping materials shall not be less than ½ inch (12.7 mm) gypsum board, 3/8-inch (9.5 mm) wood structural panels, 3/8-inch (9.5 mm) or other approved materials adequately supported. Draftstopping shall be installed parallel to the floor framing members unless otherwise approved by the building official. The integrity of all draftstops shall be maintained.

R502.13 Fireblocking required. Fireblocking shall be provided in wood-frame floor construction and floor-ceiling assemblies in accordance with Section R602.8.

R302.11 Fireblocking required Fireblocking shall be provided to cut off all concealed draft openings (both vertical and horizontal) and to form an effective fire barrier between stories, and between a top story and the roof space. Fireblocking shall be provided in wood-frame construction in the following locations:

1. In concealed spaces of stud walls and partitions, including furred spaces, at the ceiling and floor level and at 10 foot (3048 mm) intervals both vertical and horizontal and parallel rows of studs or staggered studs.
2. At all interconnections between concealed vertical and horizontal spaces such as occur at soffits, drop ceilings and cove ceilings.
3. In concealed spaces between stair stringers at the top and bottom of the run. Enclosed spaces under stairs shall comply with Section R314.8.

4. At openings around vents, pipes, and ducts at ceiling and floor level, with an approved material to resist the free passage of flame and products of combustion.

5. For the fireblocking of chimneys and fireplaces, see Section R1003.19.

6. Fireblocking of cornices of a two-family dwelling is required at the line of dwelling unit separation.

R302.11.1 Materials. Except as provided in Section R302.11 Item 4, fireblocking shall consist of the following materials:

1. 2-inch (51 mm) nominal lumber, or two thicknesses of 1-inch (25.4 mm) nominal lumber with broken lap joints.
2. One thickness of 23/32-inch (19.8 mm) wood structural panels with joints backed by 23/32-inch (19.8 mm) wood structural panels.
3. One thickness of ¾ -inch (19.1 mm) particleboard with joints backed by ¾ - inch (19.1 mm) particleboard
4. ½ -inch (12.7 mm) gypsum board.
5. ¼ -inch (6.4 mm) cement-based millboard.
6. Batts or blankets of mineral wool or glass fiber or other approved materials installed in such a manner as to be securely retained in place.
7. Cellulose insulation installed as tested for the specific application.

R302.11.1.3 Loose-fill insulation material shall not be used as a fire block unless specifically tested in the form and manner intended for use to demonstrate its ability to remain in place and to retard the spread of fire and hot gases.

R302.11.1.2 Unfaced fiberglass. Unfaced fiberglass batt insulation used as fireblocking shall fill the entire cross section of the wall cavity to a minimum height of 16 inches (406 mm) measured vertically. When piping, conduit or similar obstructions are encountered, the insulation shall be packed tightly around the obstruction.

R302.11.2 Fireblocking integrity. The integrity of all fireblocks shall be maintained.

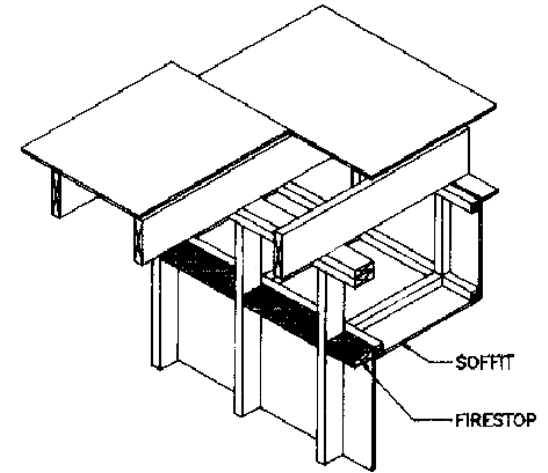

FIRESTOPPING — FURRED SOFFIT

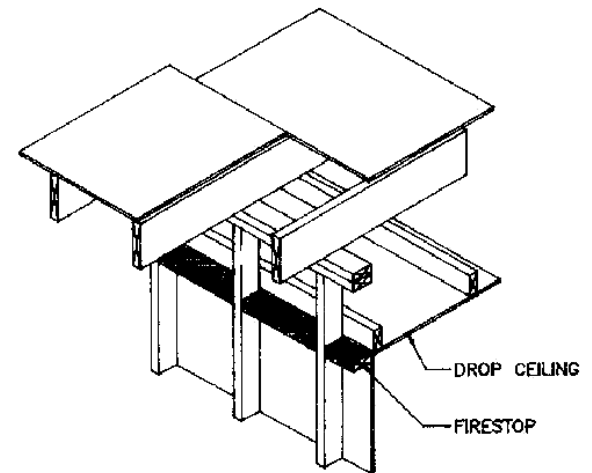

FIRESTOPPING — DROPPED CEILING

Draft-stopping & Fire-blocking

2018 KRC

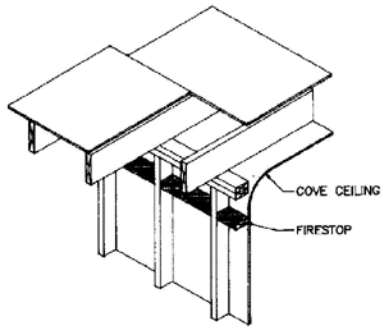

FIRESTOPPING — COVE CEILING

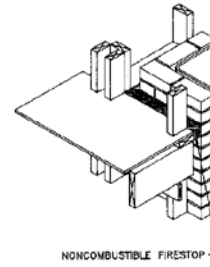
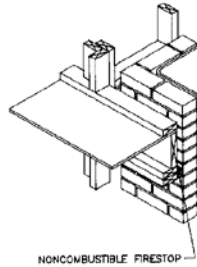
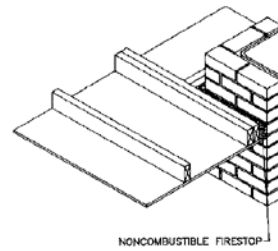

FIRESTOPPING — AROUND CHIMNEYS AND FIREPLACES

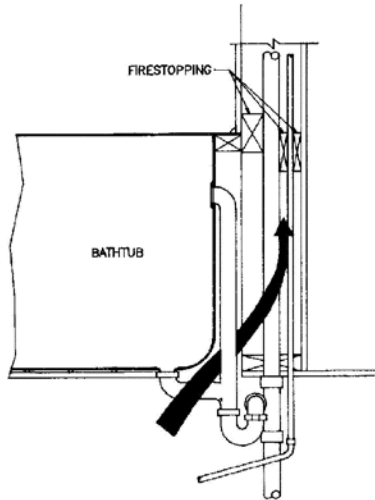

FIRESTOPPING — AT TUB

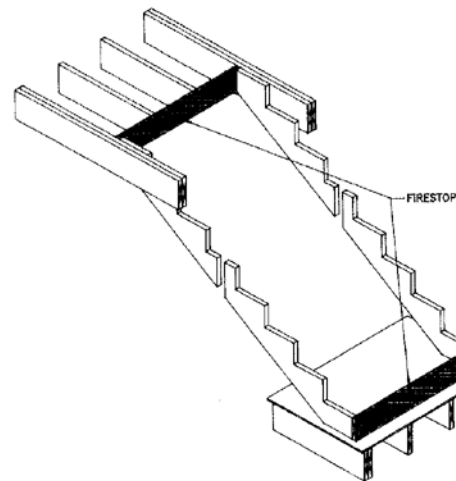

FIRESTOPPING — AT STAIRWAYS

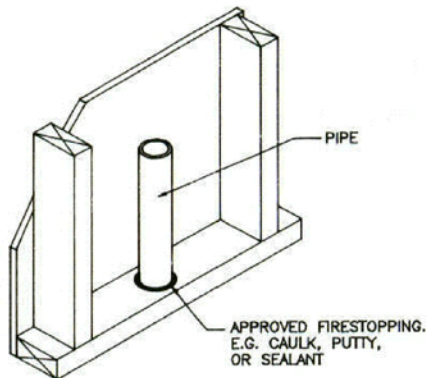

FIRESTOPPING — AROUND PIPING



City of Richmond

Department of Codes Enforcement
239 West Main Street
Richmond, KY 40475

(859) 625-6404

Monday – Friday
8:00 AM to 4:30 PM

